

HASSELBLAD®

PROFLASH 4504

User's Manual

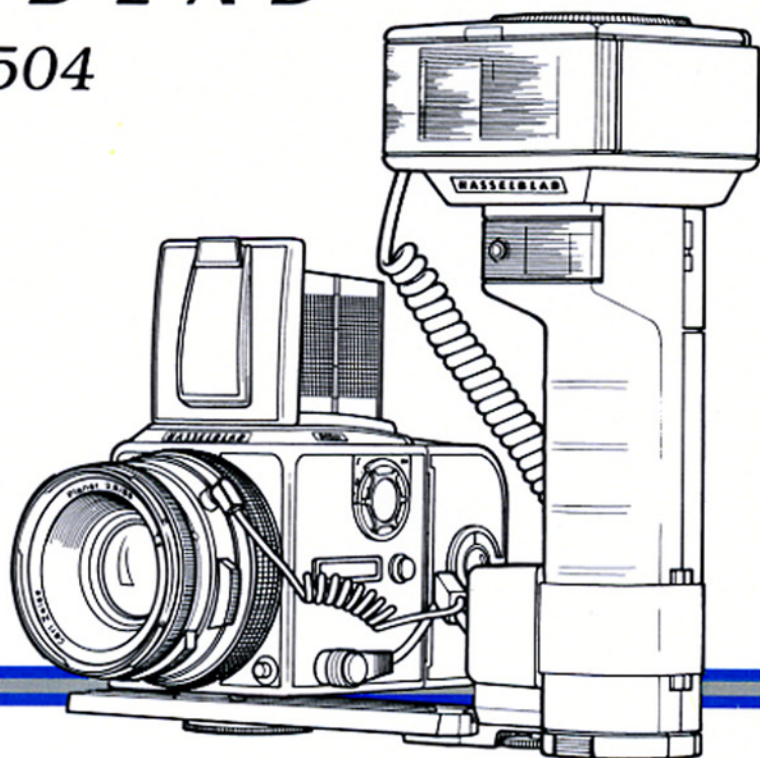

55034

HASSELBLAD PROFLASH 4504

Contents

- 2 Warranty, Maintenance and Service
- 3 About PROFLASH 4504
- 4 Delivery Package
- 6 Parts and Components
- 10 Getting Started
- 10 Charging the NiCad Batteries
- 11 Quick-start with AA Alkaline Batteries
- 12 Testing the Flash
- 12 Flash Operational Modes
- 12 TTL Mode
- 14 Automatic Mode
- 16 Manual Mode
- 19 Winder Mode
- 21 PROFLASH 4504 with Hasselblad CX and ELX models
- 21 Attaching the Flash to the Camera
 - 21 Connecting the Flash
- 23 Camera and Lens Settings
- 23 TTL setting on the Flash Control Center
- 24 Utilizing the Flash Control Center
- 25 PROFLASH 4504 with other Hasselblad models
- 25 Hasselblad 500-series, SWC and 900-series
 - 25 Connecting the Flash
 - 26 Setting the Shutter
 - 26 Hasselblad 2000-series
- 27 Attaching and Connecting the Flash
 - 27 Setting the Camera
 - 28 Setting the Flash
- 28 PROFLASH 4504 with other Cameras
- 29 Special Features
- 29 Bounce Flash
 - 29 —TTL Mode
 - 30 —Automatic Mode
 - 31 —Manual Mode
- 32 The Fill-in Flash
- 33 Accessories
 - 33 Standard Accessories
 - 33 The Fill-in Flash Reduction Filter
 - 33 Attaching the Reduction Filter
 - 33 The Wide-angle Diffuser
 - 33 Attaching the Wide-angle Diffuser
 - 35 Other Useful Accessories
 - 35 The Metz Multiconnector
 - 35 Setting up the Multiconnector
 - 36 Using the Multiconnector
 - 37 Color Filter Set
 - 37 AC Mains Power Supply
- 38 Flash TTL Close-range Chart
- 40 Guide Number Chart
- 41 Film Speed Compensation Chart
- 42 Trouble-shooting
- 43 Technical Specifications
- 44 Flash Dimensions
- 45 Suggestions for use in TTL Mode

Maintenance and Service

Protect your Proflash from moisture and excessive heat. Remove the AA alkaline batteries from the holder when not in use over long periods of time to avoid battery leakage. Excessive heat, such as direct sunshine or naked flames, may damage the batteries. Unlike NiCad batteries, the AA alkaline batteries must never be recharged.

Formation of the flash capacitor

The built-in flash capacitor may change physically when stored for long periods of time without use. To prevent such deformation the capacitor should be activated every three months by switching on the unit for about 15 minutes without firing flashes, or by operating it from the mains for 15 minutes, using the unit N22.

Prior to forming the flash capacitor we recommend recharging of the NiCad pack for five hours to compensate for self-discharging.

When service is required

Contact a center authorized by Hasselblad. The sign "Hasselblad Authorized Service Center" is your guarantee that you will be professionally received and that you can be confident of the results.

Warranty

Provided that you purchased your Proflash 4504 from an authorized Hasselblad outlet, it is covered by an international guarantee for one year from the date of purchase.

About PROFLASH 4504.

The Hasselblad Proflash 4504 dedicated electronic flash unit is the perfect complement to the Hasselblad System. Particularly designed to operate with those of the Hasselblad camera models which are provided with the TTL/OTF (Through The Lens/Off The Film) flash metering and control system, it can also be used with all other Hasselblad models as well as with any other camera.

Due to its built-in SCA-adaptor the Proflash 4504 is simple to connect since it needs one connecting cord only between the flash unit and the camera. The mode selector dial combines with an ingenious aperture/flash-to-subject distance calculator. With the tilt-and-swivel main reflector you can direct the flash straight on or bounce it any way you wish. And if you bounce it you always have the fill-in reflector for additional illumination of the subject if reequired.

The Proflash 4504 offers maximum versatility through its four operating modes — TTL, Automatic, Manual and Winder — and three different connector options — Hasselblad TTL, SCA adaptor and plain PC cord. There are also three optional power sources available — rechargeable NiCad batteries, size AA alkaline batteries or the AC mains unit in the accessory range for the Mecablitz, manufactured by Metz AG, W Germany.

Developed by Hasselblad in cooperation with one of the world's major manufacturers of high quality electronic flashes, Metz AG, and manufactured by Metz, the Proflash 4504 guarantees a long operational life and reliable function. Through the cooperation with Metz, Hasselblad gives you access to their wide range of accessories to be used with the Proflash 4504. Maintenance and service is available worldwide at the Hasselblad Authorized Service Centers.

Read this manual carefully to learn how to get the most out of your Proflash 4504 and how to expand the operational range of your Hasselblad system further.

**Hasselblad PROFLASH 4504
Delivery Package**

- A. PROFLASH 4504 Unit
- B. Wide-angle Diffuser
- C. Fill-in Flash Reduction Filter
- D. NiCad Battery Unit
(Inserted in the Flash Handle)
- E. AA Alkaline Battery Holder
- F. Camera Bracket
- G. PC Synchronization Cord
- H. Hasselblad TTL Synchronization Cord
- J. NiCad Battery Charger
- K. 1/4" to 3/8" Tripod Thread Insert

4

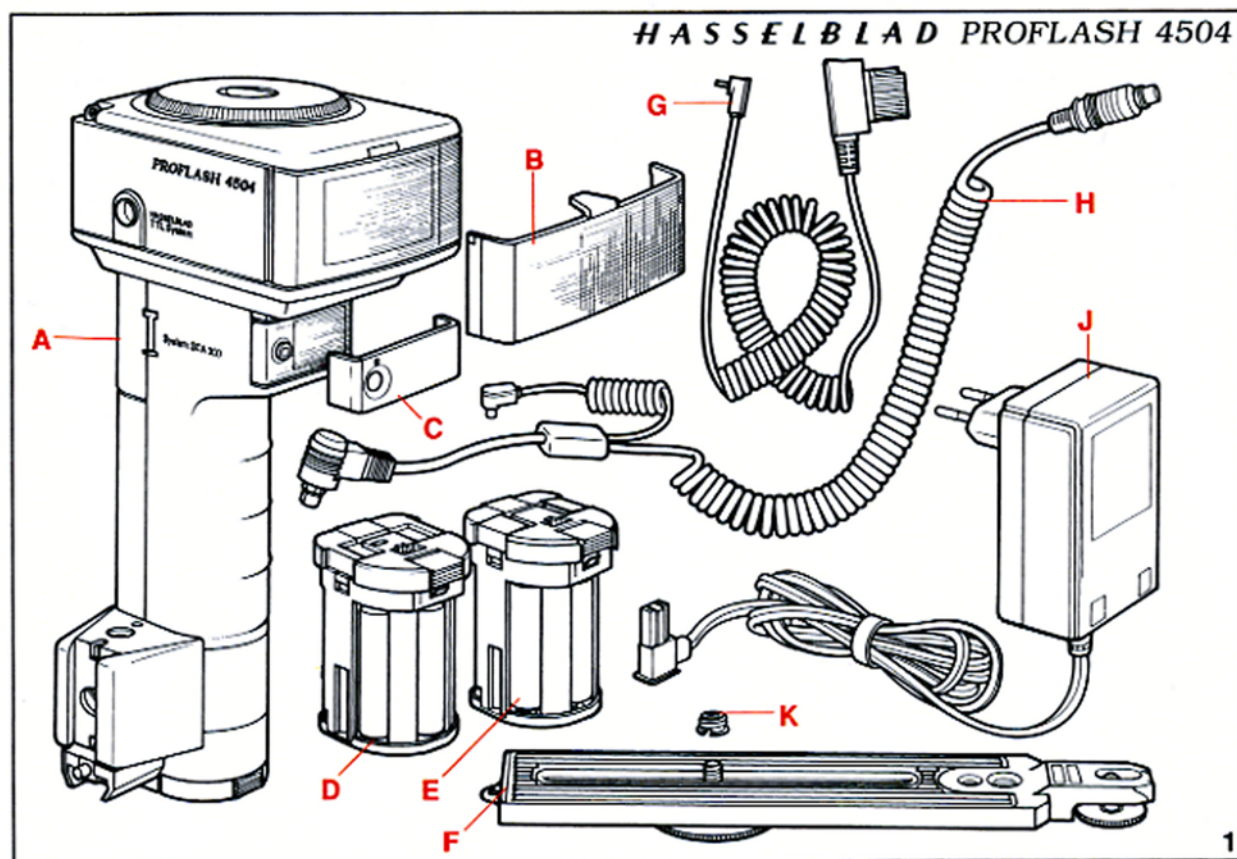

5

Parts and Components (1)

- 1 Control Center/Aperture Calculator
- 2 Shoulder Strap Eyelets
- 3 Automatic Mode Indicator "AUTO" (green)
- 4 TTL Mode Indicator "TTL" (orange)
- 5 Manual Mode Indicator "MAN" (red)
- 6 Winder Mode Indicator "WIND" (yellow)
- 7 Manual Flash Release Button
- 8 Flash Ready Indicator (green)
- 9 Auto/TTL Exposure Indicator (red)
- 10 Main Switch
- 11 Fill-in Flash Switch
- 12 Flash Handle/Battery Compartment
- 13 Retaining Strap
- 14 NiCad Battery Unit
- 15 Camera Bracket Mount
- 16 Bracket Catch Button
- 17 Bracket Stow-away Mount
- 18 SCA/PC Connector Socket
- 19 Hasselblad TTL Connector Socket
- 20 Wide-angle Shift Key
- 21 Main Reflector
- 22 Light Sensor
- 23 Fill-in Flash Reflector
- 24 Battery Compartment
- 25 Mains Power Unit Socket
- 26 Accumulator Charger Socket
- 27 Accumulator Charging Indicator
- 28 Nicad Pack Retaining Catches
- 29 Voltage Selector (certain units only)
- 30 NiCad Battery Charger
- 31 AA Alkaline Battery Holder Base
- 32 AA Alkaline Battery Holder Cage

6

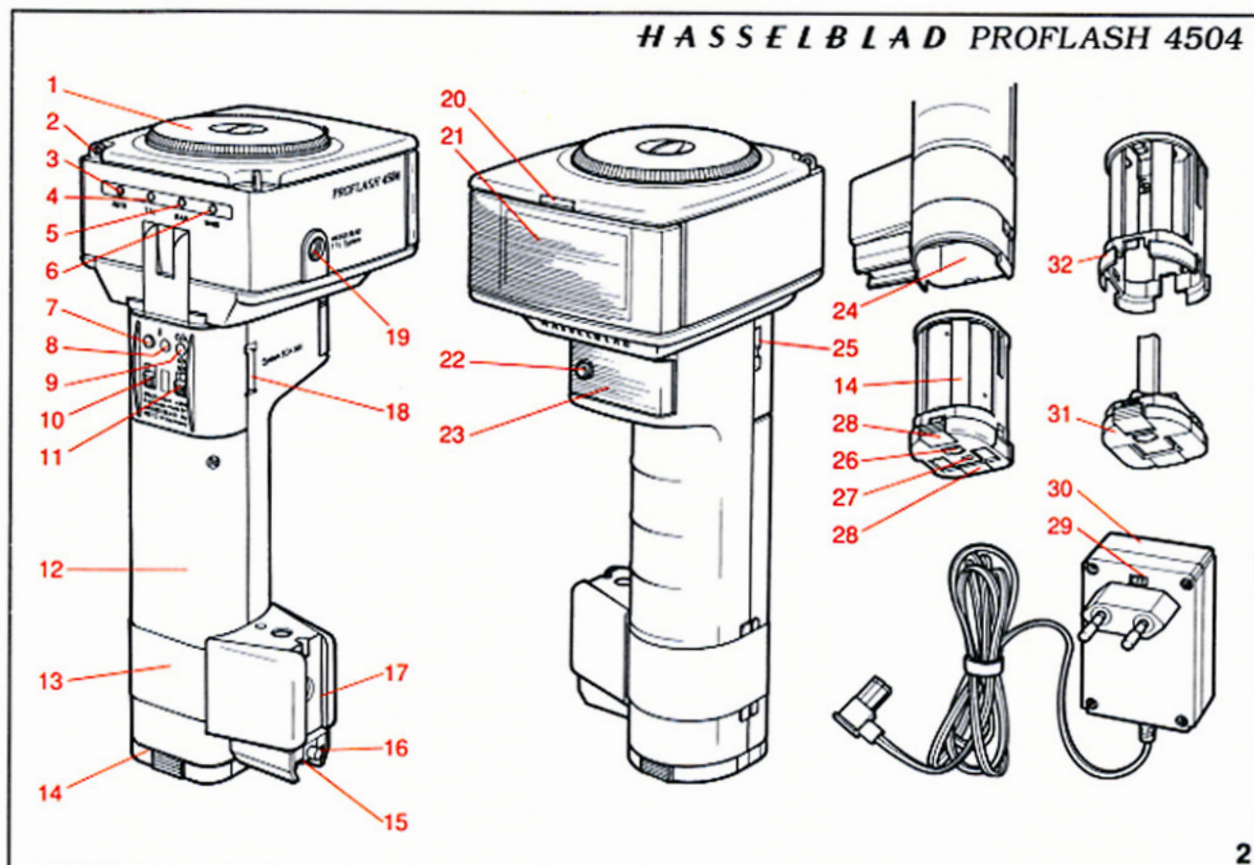

2

7

Parts and Components (2)

- 33 Aperture Settings for Automatic Mode
- 34 Mode Selector Disc
- 35 Aperture Scale for Manual Mode
- 36 Metric Distance Scale
- 37 Feet Distance Scale
- 38 Film Speed Dial
- 39 ISO/ASA Film Speed Scale
- 40 ISO/ASA Film Speed Setting Index
- 41 Winder Mode Setting Index
- 42 Manual Mode 1/4 Power Setting Index
- 43 Manual Mode 1/2 Power Setting Index
- 44 Manual Mode Full Power Setting Index
- 45 Selector Disc Index Arrow
- 46 TTL Mode Setting Index
- 47 DIN Film Speed Scale
- 48 DIN Film Speed Setting Index
- 49 SCA/PC Synchronization Cord
- 50 SCA Plug
- 51 PC Plug
- 52 TTL Camera Plug
- 53 TTL Cord PC Plug
- 54 TTL/PC Cord Branch
- 55 Hasselblad TTL Cord
- 56 1/4" to 3/8" Tripod Thread Insert
- 57 Camera Retaining Screw, 1/4"
- 58 Camera Bracket
- 59 Tripod Thread Socket, 1/4"
- 60 Tripod Thread Socket, 3/8"
- 61 Camera Bracket Locking Screw
- 62 TTL Flash Plug

8

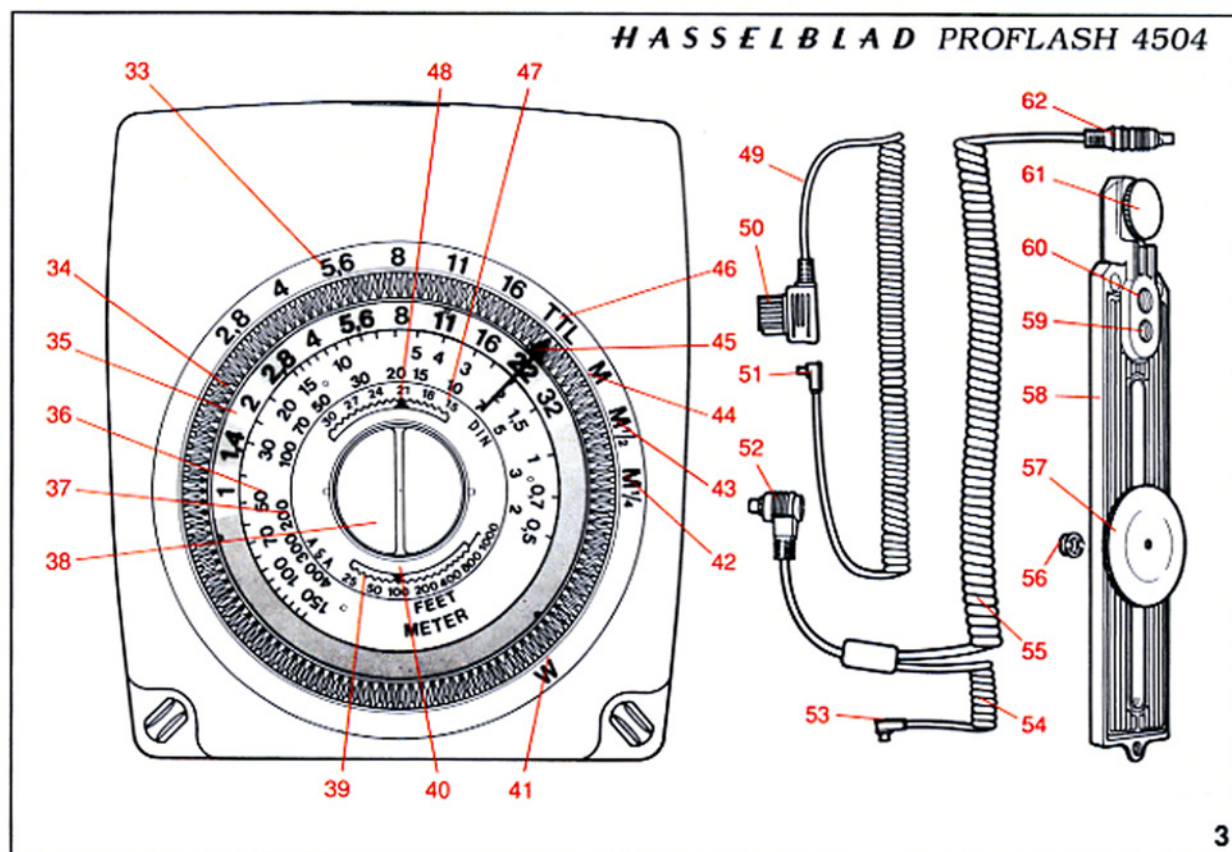

3

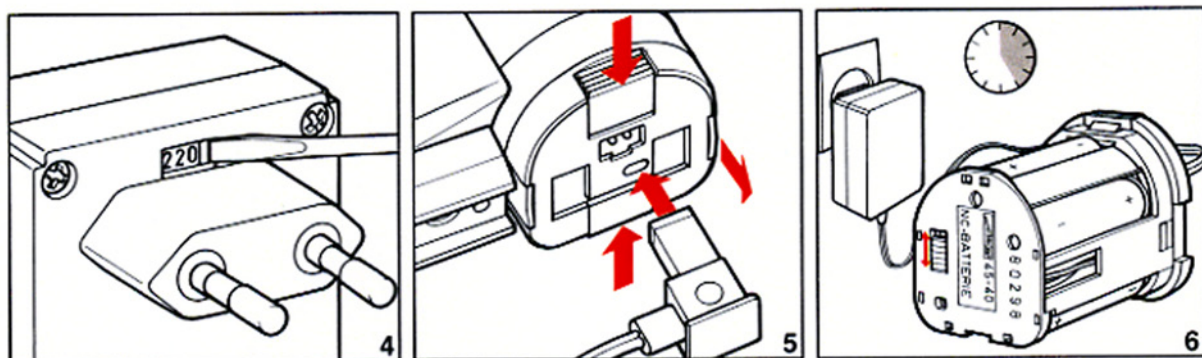

Getting Started

Charging the NiCad Battery Unit

To get started you have to charge the NiCad battery unit for 5 hours using the battery charger included in the flash package. If your charger has an opening close to the connector pins (fig. 4) displaying the voltage, ensure that it is set at the correct voltage. Otherwise it is preset from the factory. To change the setting, insert a small screwdriver in the groove at either end of the sign and push it to the other side to display the alternative voltage. Connect the charger connector to the NiCad unit's terminal and the charger to an AC mains outlet. The NiCad battery can be charged inside or outside the flash unit. To withdraw the NiCad battery unit, squeeze the two grooved buttons (fig. 5) and pull the unit out.

At the inner end of the unit is a small slider (fig. 6) which can be set at white or black. Use it as a reminder to indicate whether the unit is charged or discharged.

In continued normal use the NiCad batteries should be recharged when it takes 30 seconds or more for the "ready" light to light up when the flash unit is switched on or when the light has gone out after a full power flash.

The flash unit must be switched off when you are charging the NiCad battery inside it.

10

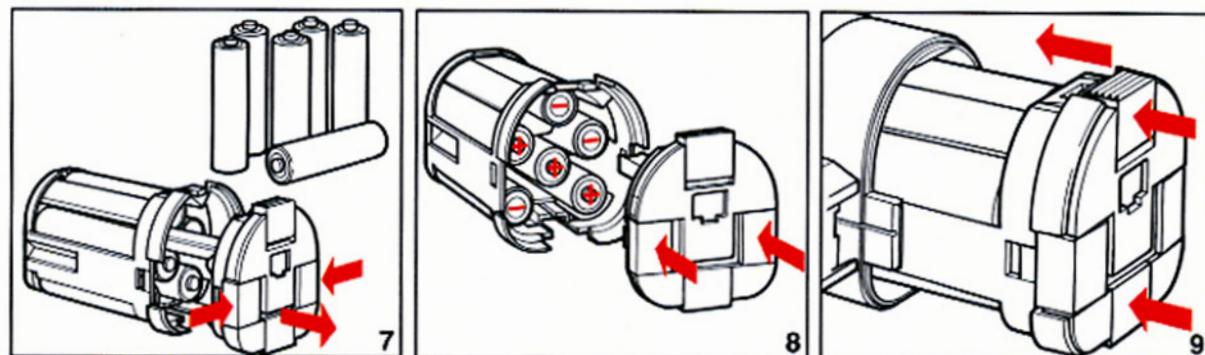

Quick-start with AA Alkaline Batteries

To avoid waiting for 5 hours to get started you can use the battery holder also included in the flash package to power the flash with 6 pcs AA size 1.5 V alkaline batteries. Open the battery holder by squeezing the two flat buttons (fig. 7) and pulling the end part out. Insert the batteries ensuring that they are inserted as indicated in fig. 8. Reattach the end part. Make sure that the catches engage properly.

Insert the holder in the flash handle, pushing at the flat surfaces of the grooved catch buttons (fig. 9). Ensure that these catches also engage properly.

NOTE: Rechargeable AA-size NiCad batteries have lower voltage and should not be used in the battery holder!

Please note that for environmental reasons alkaline batteries should not be disposed of with ordinary refuse!

11

Testing the Flash

Switch on the flash by pushing the main switch at the left on the rear of the flash handle upwards (fig. 10). When switched on the switch displays red underneath the slide button. The flash is ready to operate when the green "ready" light in the center lights up. Press the button beneath the flash mark to release the flash (fig. 11). The red "OK" light illuminates when the flash unit has provided sufficient light for the circumstances and fades out after 2-3 seconds.

Switch off the flash when it is not used to conserve power!

Flash Operational Modes

The PROFLASH 4504 operational modes are

- TTL Mode**, where the camera controls the flash output,
- Automatic Mode**, where the flash itself controls the exposure,
- Manual Mode**, where you control the exposure yourself,
- Winder Mode**, which is a manual mode with reduced power to facilitate a fast action of 2 flashes/sec.

TTL Mode

Follow this procedure to use the Proflash 4504 in TTL mode (fig. 12):

1. Turn the transparent mode selector disk to point the index arrow at the orange TTL symbol.
2. Set the film speed dial (blue ASA or DIN scale) to align the speed of the film used with the white index pointer by turning the knob in the center. The film speed and the distance scales move together.
NOTE: The film speed setting does not affect the function of the flash.
3. Read the maximum flash-to-subject distance straight below the value of the aperture to be used. The minimum distance for full TTL flash control is shown in the table on page 39.

Regarding use of Wide-angle Diffuser for parallax compensation at short flash-to-subject distances please see page 33.

When you switch on the flash, the orange "TTL" indicator lights up (fig. 11). The green "ready" light on the back of the handle lights up when the flash is ready to operate and goes out only if most of the flash power has been used for the flash. The red "OK" indicator lights up when the flash output was satisfactory and fades out after 2-3 seconds.

See page 21 how to use the Proflash 4504 with the Hasselblad TTL/OTF flash metering cameras!

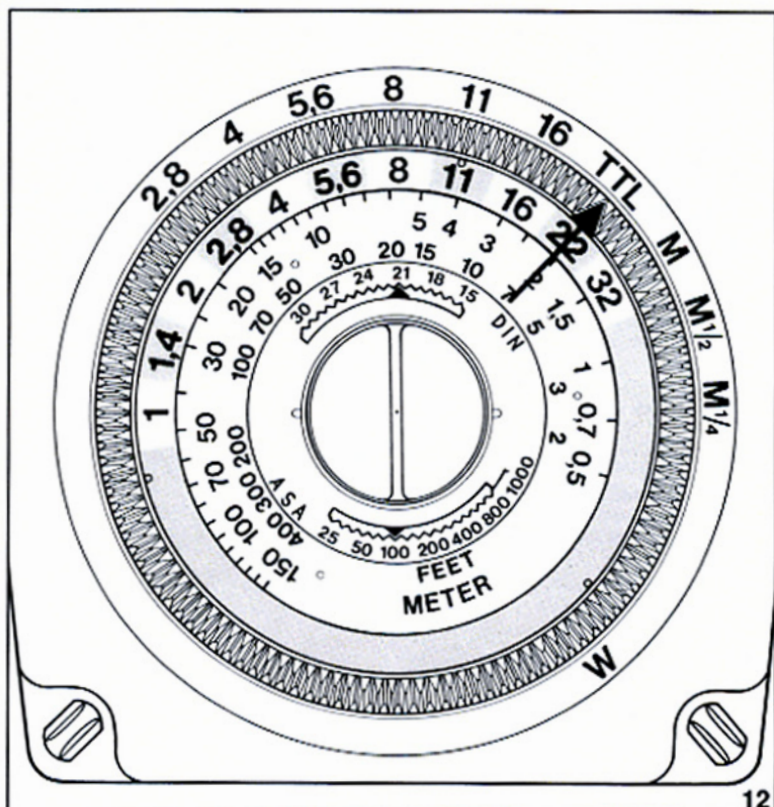
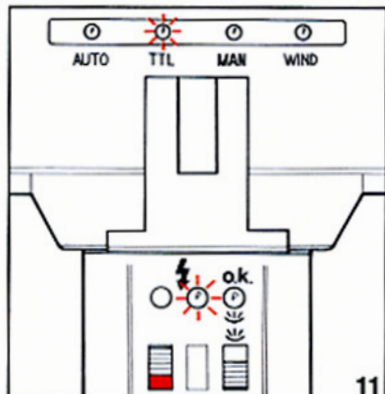
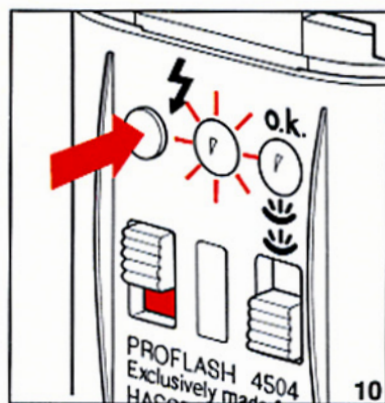

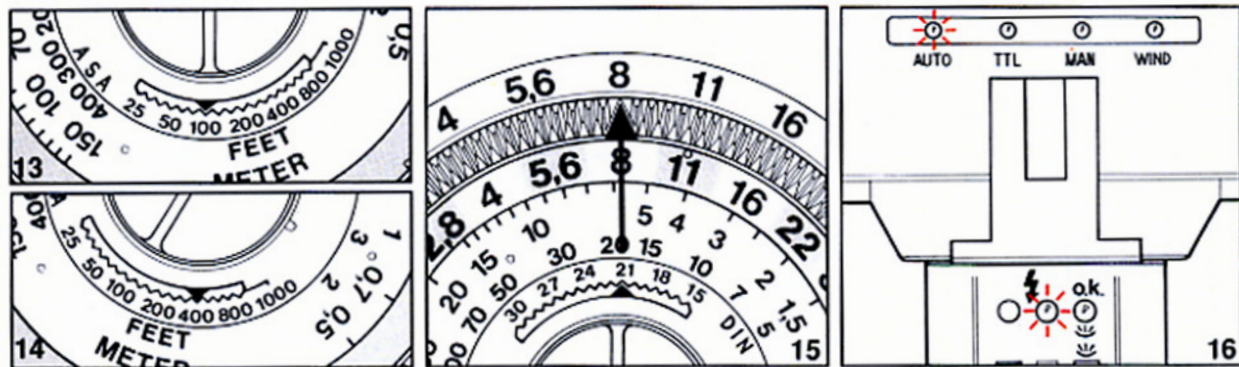

Automatic Mode

In Automatic mode the Proflash 4504 gives a correct over-all exposure and can be used with any camera, since the built-in metering system in the flash works independent of the camera to which the flash is connected. The flash settings are identical in all cases:

1. Set the film speed dial (blue ASA or DIN scale) to align the speed of the film used with the white index pointer by turning the knob in the center. The film speed and the distance scales move together (figs. 13,14)
2. Rotate the transparent mode selector disk to align the index arrow with the green aperture value corresponding the aperture to be used or to match the distance between the flash and the subject (fig. 15). The green "AUTO" indicator light turns on (fig. 16) when the flash is switched on.
3. Read the **maximum** flash-to-subject distance straight below the value of the aperture to be used or read the **largest** aperture value to be used for the apparent flash-to-subject distance. The minimum distance for fully automatic flash control is approximately 10% of the maximum distance. Subjects beyond the maximum distance will be underexposed and subjects closer than the minimum distance will be overexposed.

14

Example 1:

Flash-to-subject distance: 2.5 m (8 ft)
 Film speed: ISO(ASA) 100/21°

Procedure: Set the film speed (p.2, page 14). In this example the flash-to-subject distance falls between the shortest maximum distance to be read at the available apertures (3 m at 16) and the minimum distance (0,3m) according to p.3 above. Thus, you can chose any of these apertures, e.g. f/16 for larger depth-of-field. Turn the selector disk to point the index arrow at the green number 16 and also set your camera aperture at f/16.

Example 2:

Flash-to-subject distance: 8 m (26 ft)
 Film speed: ISO(ASA) 400/27°

Procedure: Set the film speed (p.2, page 14). The flash-to-subject distance 8 m can be read at the aperture 8. Thus, you can use any of the aperture settings giving you an equal or larger maximum distance, i.e. 2.8, 4, 5.6 and 8. E.g. you can chose 2.8 for the shallowest depth-of-field. Set the index arrow on the selector disk at the green value 2.8 and your camera aperture at f/2.8.

When you switch on the flash, the green "AUTO" indicator lights up, as does the green light on the back of the handle when the flash is ready to operate (fig. 16). The red "OK" indicator lights up if the exposure was satisfactory and fades out after 2-3 seconds. The green "ready" light stays on if the flash did not use all of the power and the remaining power is sufficient for a new flash.

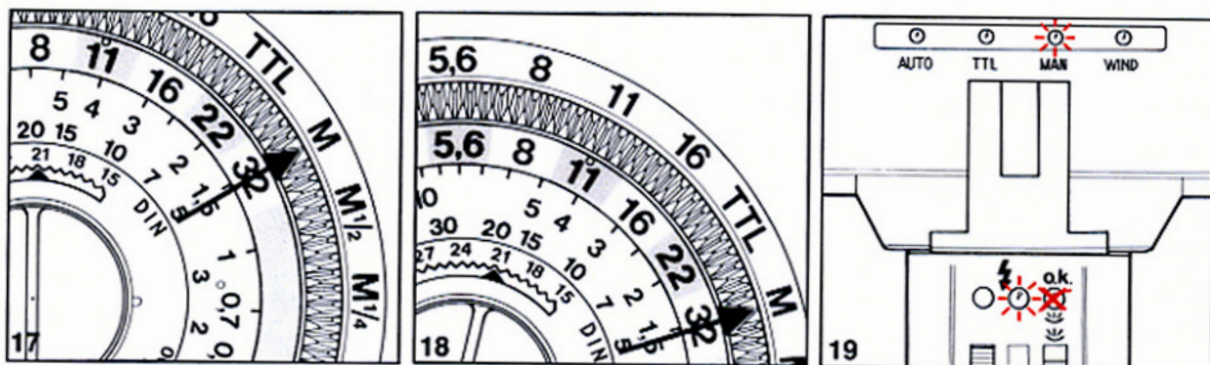

Manual Mode

The Manual mode has three different settings:

- M** for full power,
- M1/2** for half power and
- M1/4** for one quarter of the full power output.

The different settings are selected with the transparent selector disk by pointing the index arrow at the corresponding symbol. The distance scale and the selector disk move together to the M1/2 and M1/4 settings to give proper distance readings when you are using the flash at reduced power.

When the flash unit is switched on the red "MAN" indicator lights up, as does the green "ready" light when the unit is ready to operate. The "OK" light goes on and off but has no relevance in the Manual mode (fig. 19).

In the Manual mode the setting of the camera aperture is dependent on the flash-to-subject distance and the **Guide Number** of the flash unit for the film speed used (see table, page 40). Every change in flash-to-subject distance requires a corresponding change in camera aperture setting. The camera aperture to be set for a certain distance is best determined by means of the **Control Center** (see fig. 12, page 13).

Using the Control Center

Set the film speed by turning the center knob.

Turn the selector disk to point the index arrow at the red **M** (fig. 17) to select Manual mode with full output power. Now you can read the aperture to be set on your camera from the black and white aperture scale directly above the actual flash-to-subject distance (fig. 18).

16

Example 1:

Using the control center

Film speed: ISO(ASA) 100/21°
Flash-to-subject distance: approx. 8 m
Aperture setting: $f/5.6$

Example 2:

Using the Guide Number

To determine the aperture required for a certain flash-to-subject distance use the method below:

$$\text{Camera aperture} = \frac{\text{Guide Number}}{\text{Flash-to-subject distance}}$$

Referring to the previous example:

Guide number for ISO 100/21° film from the table on page 40: **45**
Flash-to-subject distance: **8 m**

$$\frac{45}{8} = 5,625; \text{ Camera aperture} = 5,6$$

If necessary round the calculated figure up or down to correspond to the nearest possible camera setting.

When you are using the **wide-angle diffuser** you have to open up the camera aperture one full stop, i.e. set 4 instead of 5,6 in this example.

17

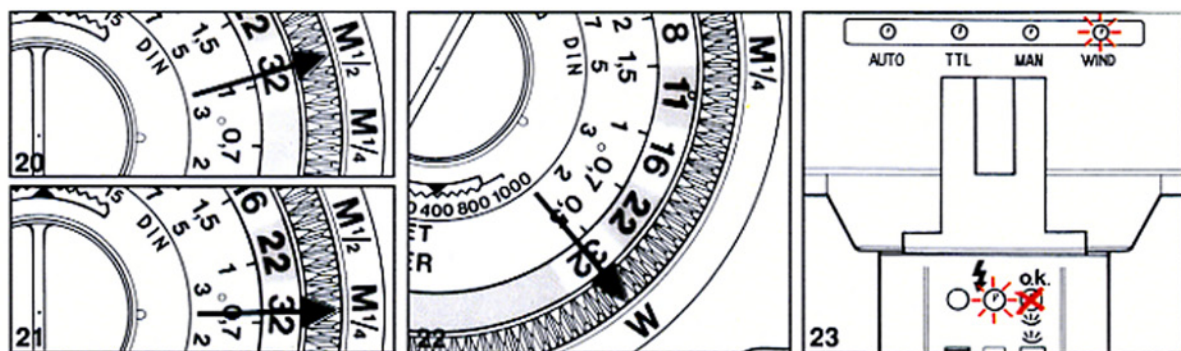

Using the Reduced Flash Output

In the Manual mode you can select two settings with reduced light output, **M1/2** with 50% (fig. 20) and **M1/4** with 25% (fig. 21) output. The output reduction is achieved by reducing the flash duration to 1/1000s and 1/2500s respectively. Since less power is used for these flashes the recycling time is proportionally shorter. The illumination of the "OK" light is not relevant in these modes and should be disregarded (fig. 19)

To select the reduced output you follow the procedure described on page 16, but you turn the selector disk to point the index arrow at the M1/2 or M1/4 setting. You can read the required camera aperture setting for the actual flash-to-subject distance from the black and white aperture scale directly above that distance.

Examples to the use of Reduced Flash Output

The reduced output modes are particularly useful when the flash-to-subject distance is very short or when a short exposure is required to capture a moving subject.

Example 1: Short flash-to-subject distance.

Film speed: ISO(ASA) 200/24°
Flash-to-subject distance: 1.5m (5 ft)
Smallest camera aperture: 1/22

When using the full output the aperture calculation will be:

Guide number/Distance = Aperture $64/1.5 = 43$ Not available!

Change to 1/4 output. Guide number factor = 0,5 (page 40)

Guide number: $64 \times 0,5 = 32$ $32/1,5 = 21,3$ **22**

Example 2:

A sharp image of a fast moving subject is required which calls for a short flash duration. In the TTL or Automatic modes the flash duration is not defined. The alternative is Manual mode with reduced output where the flash duration is both well known and sufficiently short.

18

Winder Mode

The Winder mode is a variety of the Manual mode with further reduced output to facilitate a flash sequence of 2 flashes/second. The flash output is 1/40 (2,5%) of the full output and the Guide Number Factor is 0,16 (see page 40). The flash duration is approx. 1/10000 second.

You select the Winder mode by turning the selector disk to point the index arrow at the **W** symbol (fig. 22). The aperture scale is automatically adjusted to correspond to the reduced guide number. When you switch on the flash unit the yellow "WIND" indicator lights up, as does the green "ready" light when the flash unit is ready to operate. The red "OK" light is not relevant in the winder mode and should be disregarded (fig. 23).

NOTE: In Winder mode the PROFLASH should be powered by NiCad batteries only!

Example 1:

A sports event requires a winder sequence of images. The flash-to-subject distance is 5m (17 ft) and the largest available lens aperture is 1/4. Which is the slowest film speed to be used?

Procedure:

Turn the selector disk to point the index arrow at **W**.

Turn the central knob to set the distance 5m at the aperture figure 4 on the black and white aperture scale.

Read the required film speed ISO(ASA) 800/30° off the blue ASA/DIN film speed scales.

Example 2:

An image of a fast moving machinery part requires the shortest possible exposure. The flash-to-subject distance is 1,5m (3 ft) and the speed of the film used is ISO 200/24°.

Which aperture should be used?

Procedure:

Turn the selector disk to point the index arrow at **W** to select a flash duration of 1/10000 second.

Turn the center knob to set the film speed 200/24°.

Read the applicable aperture to between 5,6 and 8 above the distance mark 1,5(m).

If you require the accurate aperture figure you have to calculate:

Guide number **64** for film speed ISO 200/24°

Reduction factor **0,16** (page 40) $64 \times 0,16 = 10,24$ $10,24/1,5 = 6,8$

19

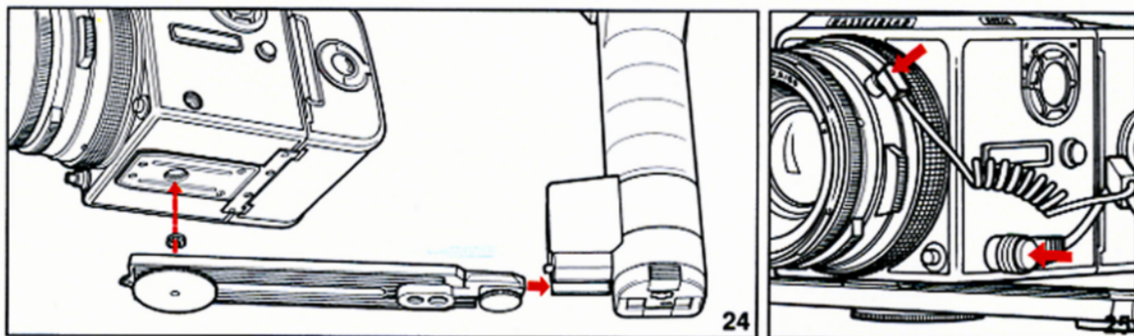

PROFLASH 4504 with Hasselblad CX and ELX models

Attaching the Flash to the Camera

Use the camera bracket to attach the flash unit to the camera (fig. 24). The large retaining screw in the bracket has a 1/4" thread. Insert the thread reduction bushing into the camera tripod mount if that has a 3/8" thread. First attach the bracket to the camera and then fit the dovetail mount of the flash unit to the dovetail end of the bracket. Tighten the flash retaining screw on the bracket to eliminate the play in the mount. To detach the flash unit from the bracket release the retaining screw, press the catch button in the mount and withdraw the unit.

Connecting the Flash

Use the TTL cord to connect the flash unit to the camera. The cord has two female six-socket TTL plugs and a branched-off cord with a PC plug. Insert the L-shaped TTL plug into the TTL socket in the camera body and the PC plug into the PC terminal on the lens (fig. 25). Please observe that the cord exit on the L-shaped TTL plug should point towards the rear of the camera.

(continued on page 22)

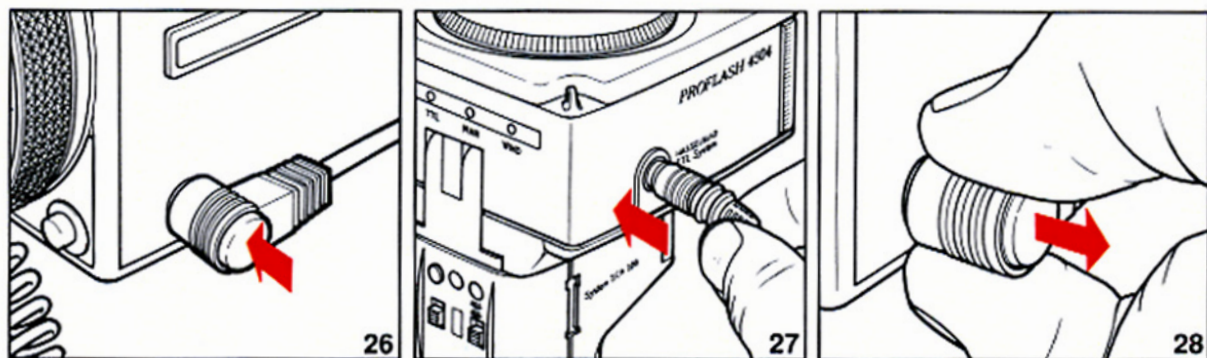

Insert the straight TTL plug into the TTL socket on the right hand side of the flash head (fig. 27). Rotate the plug to match the groove on the plug-in part with the corresponding lug in the socket. When inserting the TTL plugs, do not grip on the metallic sleeves but on the black plastic parts and push the plugs straight into the socket mounts. On the L-shaped plug push at the flat top surface (fig. 26). The plugs lock in the sockets with an audible click.

To disconnect the TTL plugs, grip at the metallic sleeves and pull straight out (fig. 28).

You can also connect the flash through a Hasselblad SCA 390 Flash Adapter but then you will need an additional cable SCA 300A supplied by METZ, West Germany.

Camera and Lens Settings

When you are using the TTL/OTF flash control system in the 503CX, 500ELX or 553ELX, the only setting you need to do on the camera, except the normal lens settings, is the film speed dial.

NOTE: The TTL system measures the light reflected from the film surface. The degree of reflection varies between different films depending on the color and structure of the film surface. The best way to compensate for the variations is to alter the film speed setting. You are recommended to make several trial shots to determine the film speed setting for the film you are using. See the table on page 41 for a review of suggested settings for different films.

22

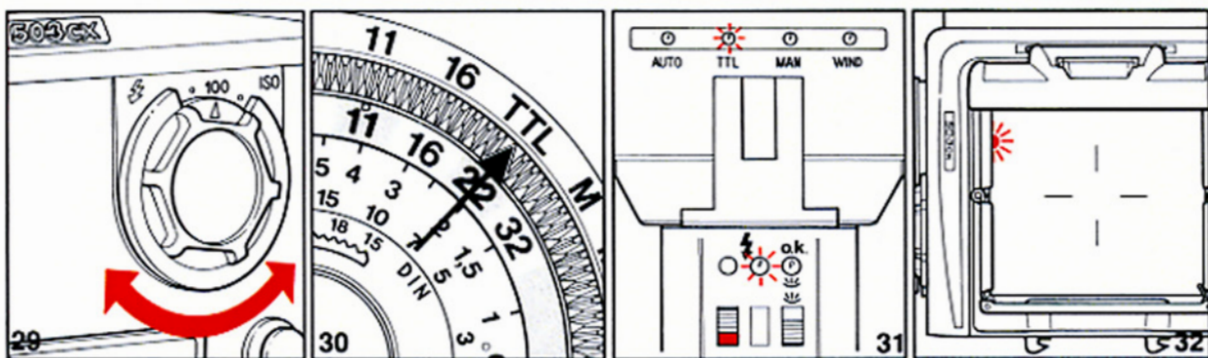

This is the dial on the left hand side of the camera, above the strap lug (fig. 29). The setting range of the dial is from ISO 16/13° to ISO 1000/31° with intermediate click stops between the noted values as indicated in the complete scale illustrated below. Please observe that ISO 1000 is represented by a dot mark.

When the full flash power is used, e.g. at long flash-to-subject distances, the flash duration is approximately 1/300 s. Using the fastest shutter speeds (1/250, 1/500 s) may then result in an underexposure of subjects at the far limit of the flash range. **To avoid that, you are recommended to use shutter speeds of 1/125 s or slower whenever possible.**

TTL setting on the Flash

Select the TTL mode by rotating the transparent selector disk to position the index arrow at the orange TTL mark (fig. 30). This is the only setting you need to do to use the flash in TTL mode.

Switch on the flash unit with the main switch (fig. 10). The orange TTL index light on the back of the flash head lights (fig. 31). When the flash is operative, the green "ready" light on the flash and the red index light (fig. 32) in the camera viewfinder light up.

ISO/ASA	16	•	25	•	40	•	64	•	100	•	•	200	•	•	400	•	•	800	•
DIN	13	14	15	16	17	18	19	20	21	22	23	24	25	26	27	28	29	30	31

23

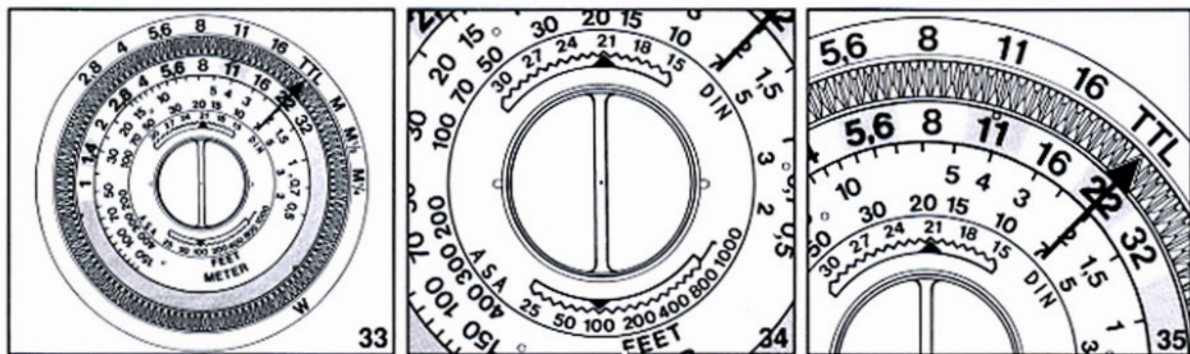

Utilizing the Flash Control Center

In TTL mode the control center scales (fig. 33) can be used as a flash illumination range calculator and a film speed reminder. The film speed setting does not affect the flash operation in this mode.

To find the maximum range of the flash, set the film speed by rotating the central knob until the film speed is positioned opposite the white index mark (fig. 34). Observe that when rotating the knob you move the blue film speed scales, not the index marks. With the film speed set you can read the maximum flash range below the aperture numbers on the black and white aperture scale (fig. 35).

Example: With the disk arrow set at TTL and the film speed set at ISO(ASA)100/21° you read 8m at f/5.6 or 4m at f/11 etc.

NOTE: The readings described above denotes the far limit of the flash range and the aperture range for medium speed films. For the near limits and the aperture ranges for slower and faster films see the table on page 39!

24

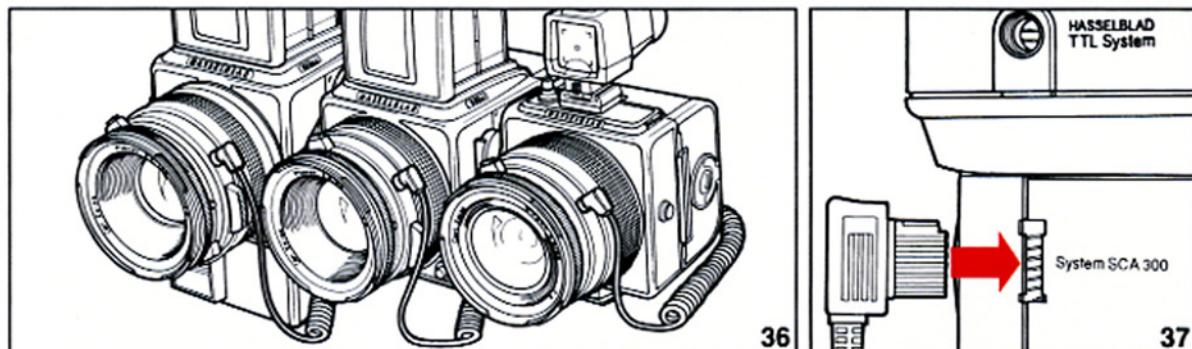

PROFLASH 4504 with other Hasselblad Models

Hasselblad 500-series, SWC and 900-series

The PROFLASH 4504 can be used with the earlier Hasselblad models 500C, 500C/M, 500EL, 500EL/M, SWC, SWC/M and also with 903SWC as these models all have built-in leaf shutters in the lenses. However, since they have no light sensors in their bodies, the TTL mode cannot be used. Instead the flash must be operated in Automatic, Manual or Winder mode when used with these cameras.

The flash unit can preferably be attached to the cameras as described in page 21.

Connecting the Flash

To connect the flash unit to these cameras you should use the PC cord included in the delivery pack. Insert the flat connector of this cord into the System SCA 300 socket and the PC plug in the other end of the cord into the PC terminal at the lens as illustrated above (fig:s. 36, 37) and in page 26 (fig:s. 38, 39).

25

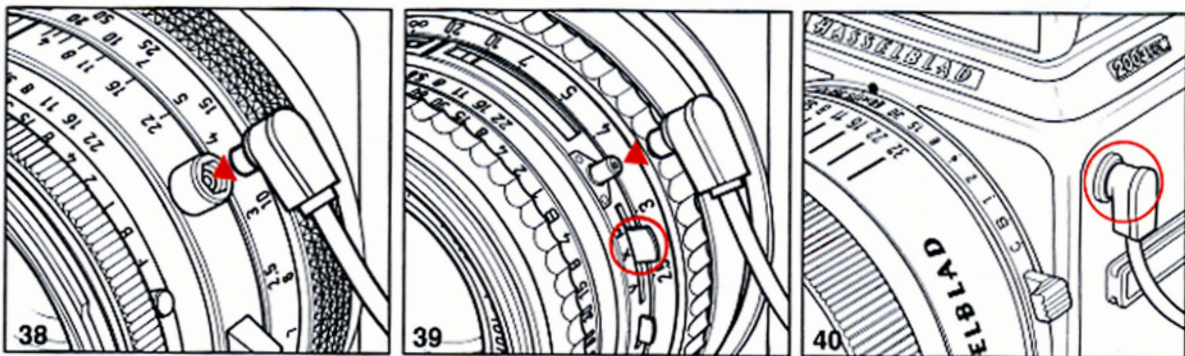

Setting the Shutter

When you are using a CF-lens (fig. 38) no further setting is required for the shutter or the camera.

On a C-lens the synchronization mode selector should be set to X-mode to avoid exposure errors (fig. 39).

No other particular settings are required to use the Proflash 4504 with these models. The further procedure is depending on what operational mode you select for the flash unit (see page 12).

Hasselblad 2000-series

The Hasselblad 2000-series models (fig. 40) have a focal plane shutter in the camera body for use with F-lenses with no built-in shutters or with CF-lenses in F setting. The fastest shutter speed for synchronization of electronic flashes is 1/90 s, which is marked with a X symbol on the shutter speed ring (fig. 41).

For further information on the use of Proflash 4504 with the Hasselblad 2000-series please refer to the Instruction Manual for the camera.

26

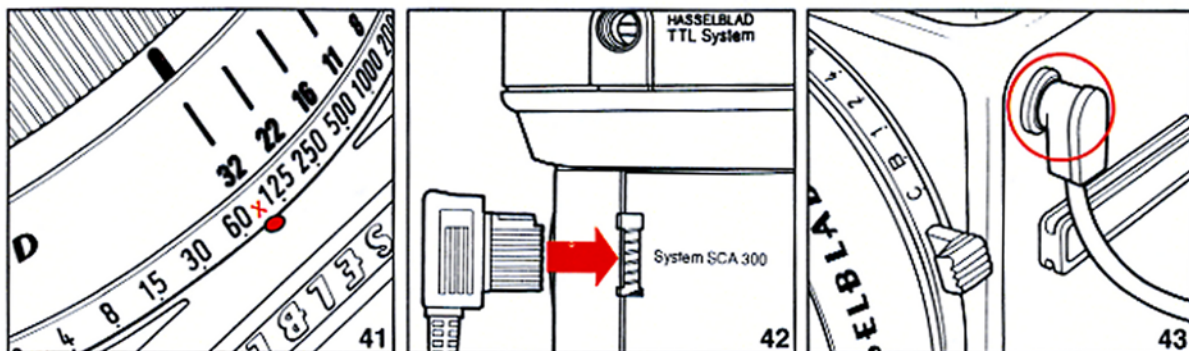

Setting the Camera

The only setting required on the camera is to set the shutter speed ring at the X symbol corresponding to 1/90 s (fig. 41) or at a slower speed if called for by the circumstances. Please observe that at speed settings faster than 1/90 s the triggering of the flash is inhibited.

Attaching and Connecting the Flash

You attach the flash to the camera in the same way as described for the 500-series models (see page 21). The SCA system cannot be used since the 2000-series cameras have no TTL/OTF metering system. The only synchronization connector is the PC terminal which on these cameras is located in the upper front corner on the left hand side of the camera body (fig. 40).

To connect the flash unit to any of these cameras you should use the PC cord included in the delivery pack. Insert the flat connector of that cord into the System SCA 300 socket on the right hand side of the flash handle (fig. 42) and the PC plug in the other end of the cord into the PC terminal in the camera body (fig. 43).

27

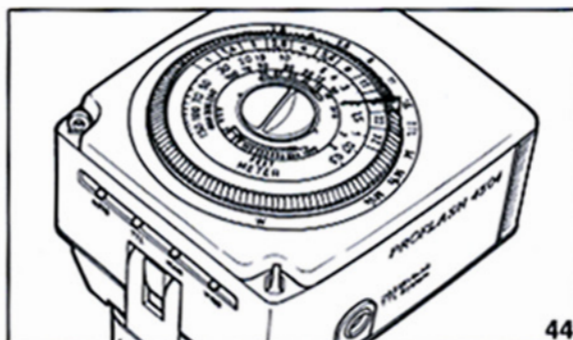

Setting the Flash

The flash can be operated in either of Automatic, Manual or Winder modes (see page 12).

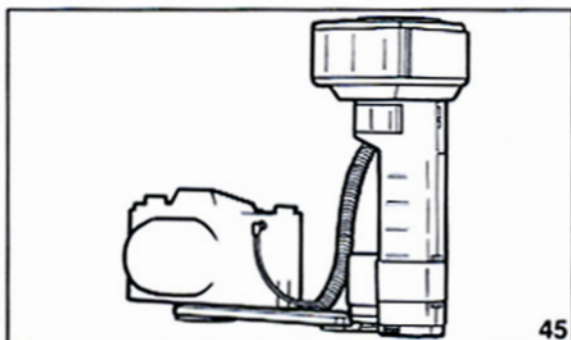

PROFLASH 4504 with other cameras

The PROFLASH 4504 can be used with any camera with adequate flash synchronizing function (fig. 45). To utilize the TTL function of the flash however, provided that the camera has a TTL metering system, a suitable SCA adapter must be used, connected to the System SCA 300 socket in the flash. Otherwise the PC cord should be used. The PC cord should always be connected between the System SCA 300 socket and the PC terminal. You can use the flash in any operational mode, depending on the function of the camera.

28

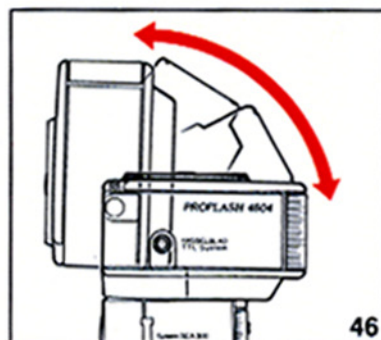

46

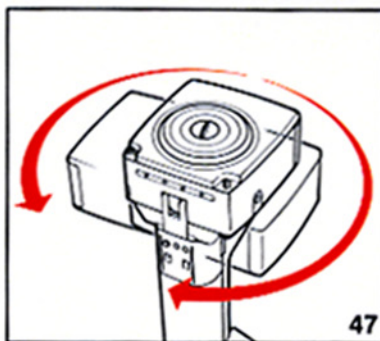

47

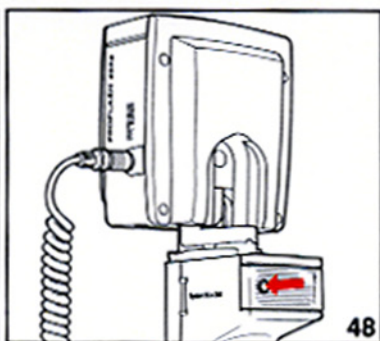

48

Special Features

Bounce Flash

Direct frontal flash illumination usually produces very harsh shadows in the subject. The most common way to avoid this is to direct the flash away from the subject, preferably towards a well reflecting surface, such as a white ceiling, i.e. to "bounce" the flash. To facilitate this the main reflector of the PROFLASH 4504 can be tilted to a vertical position (fig. 46) and also rotated 180° in either direction (fig. 47).

The light sensor, however, is located in the handle (fig. 48) and should always be directed towards the subject. The Control Center cannot be used to determine aperture or range when you are using "bounce flash" technique.

29

Bounce Flash in TTL Mode

Set the mode selector disk on the flash at TTL (fig. 49). If the flash is directed to bounce from a normally white ceiling at a normal height it is reasonable to start with a lens aperture setting about two stops larger than required for a direct frontal flash. Make trial exposures at different apertures, closely observing the "OK" indicator light on the flash or in the viewfinder (fig. 33, page 23).

Please keep in mind that you must have the proper type of film in the magazine to obtain a reliable TTL metering result. You can make the test exposures on the same film frame, using the "multiple exposure" routine.

Bounce Flash in Manual Mode

Using the bounce flash technique in Manual mode is rather difficult and unsafe and should be avoided if possible. If it has to be done, however, there are a couple of "thumb rules" that may help when you calculate the aperture by means of the guide number. In a small room with a white ceiling at normal height you can double the flash-to-subject distance and use that in your calculation. In a larger room and/or higher ceiling you could estimate the total distance from the flash to the ceiling to the subject in your calculation and then open up the camera aperture one or more stops (fig. 51). In either case you are recommended to make more exposures at different settings.

Bounce Flash in Automatic Mode

Direct the flash sensor towards the subject. Fire test flashes manually while changing the aperture setting on the flash control center to find out and verify the correct one, carefully watching the "OK" indicator light (fig. 50). When the "OK" light indicates sufficient flash output, set the lens aperture at the same value.

30

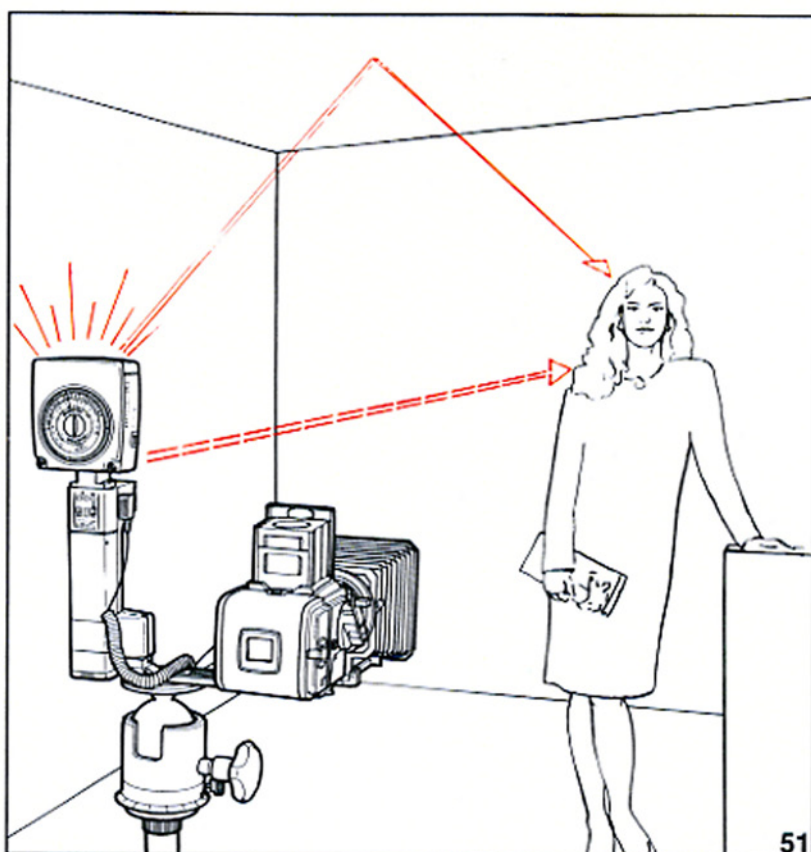
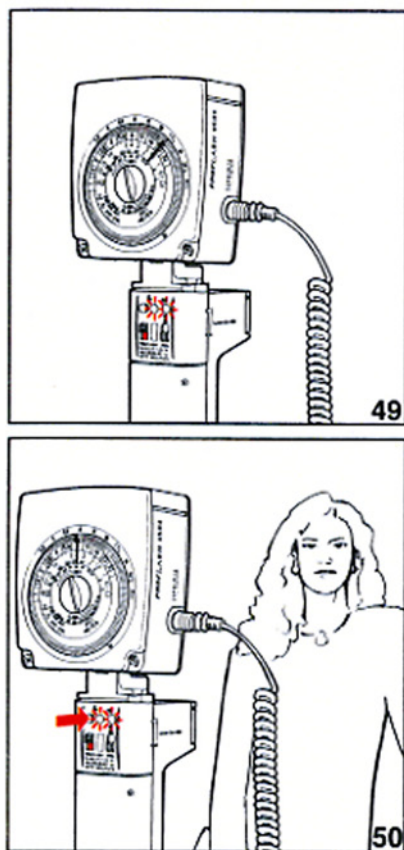

31

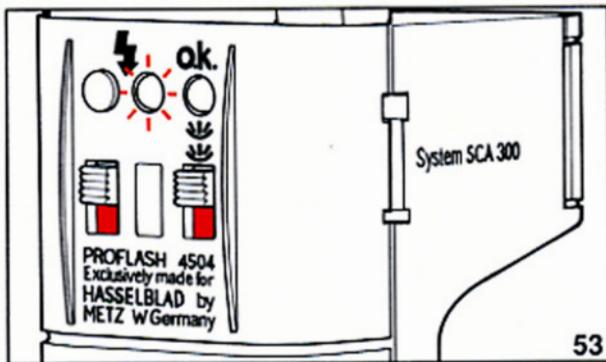
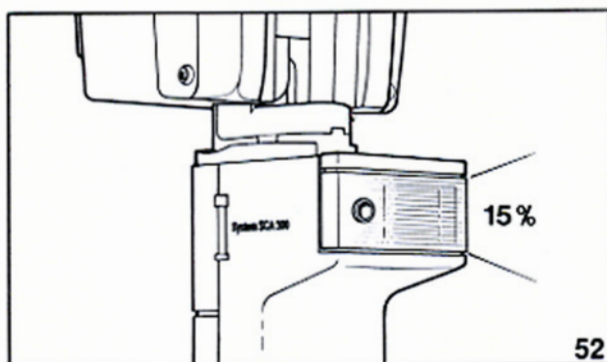

The Fill-in Flash

The Fill-in flash located below the main flash reflector (fig. 52) should be used to obtain a certain degree of front illumination when the main reflector is tilted or turned away from the subject for bounce flash effects. The output distribution between the two reflectors are 85% on the main and 15% on the fill-in reflector.

The use of bounce flash with fill-in flash is recommended in TTL and Automatic modes only. For direct frontal flash the main reflector alone should be used.

The fill-in flash is operated by the slide switch marked by a double reflector symbol to the right at the rear of the flash handle, below the "OK" indicator (fig. 53). To switch it on you slide the switch button upwards. In the ON position the switch displays a red signal below the switch button.

32

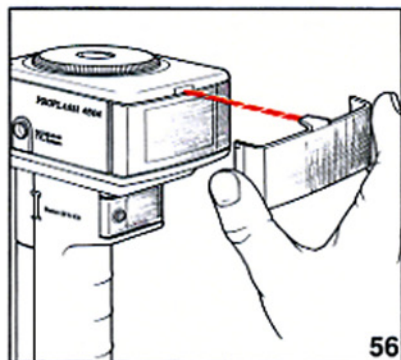
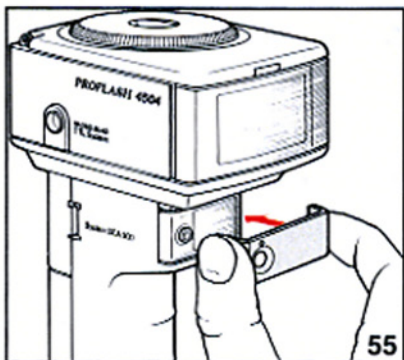
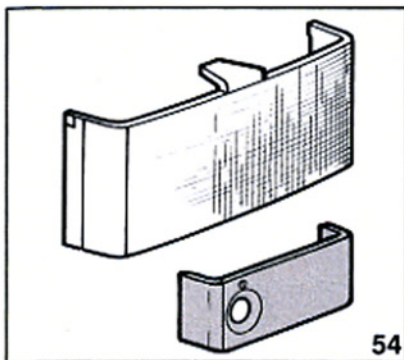

Accessories

Standard Accessories

The Fill-in Flash Reduction Filter

When you are using bounce flash technique with frontal fill-in addition it is sometimes desirable to soften the frontal flash. For this purpose the PROFLASH 4504 delivery package includes a fill-in flash reduction filter (fig. 54, bottom).

When the filter is attached the light from the fill-in flash is reduced by approximately 60%.

Attaching the Reduction Filter

Locate the U-shaped filter on the fill-in flash making sure that the circular sensor window beside the reflector is not obscured (fig. 55). Press the filter against the flash to engage the snap fit on both sides.

To remove the filter, pull firmly outwards at one side.

The Wide-angle Diffuser

The illumination angles of the main reflector in the PROFLASH 4504 are 62° horizontally and 42° vertically, covering the image area of lenses with focal lengths of 80 mm and up.

To increase the coverage to a focal length of 50 mm and to compensate for parallax differences at short flash-to-subject distances a Wide-angle diffuser (fig. 54, top) is included in the PROFLASH 4504 delivery package. With the diffuser attached the vertical illumination angle is increased to 60°. Attaching the diffuser reduces the guide number of the flash unit corresponding to one full aperture stop, but the reduction is automatically performed on the control center. Thus, when using the control center you need not consider this, but when calculating the aperture using the guide number the camera should be opened up one full stop from the calculated aperture.

Attaching the Wide-angle Diffuser

The U-shaped diffuser screen has a central lug protruding from one edge. In the top center of the main reflector is a small opening covered by a flap. When you attach the screen to the main reflector you should locate it to insert the lug into that opening (fig. 56) and push it firmly towards the reflector until the snap fit at both sides engage. Inserting the lug performs the change in the control center.

To remove the diffuser screen, pull firmly outwards at one side.

33

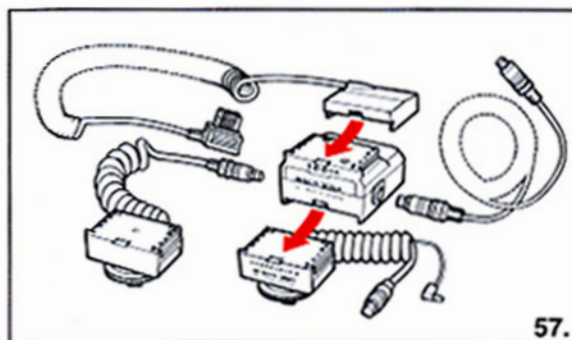

57.

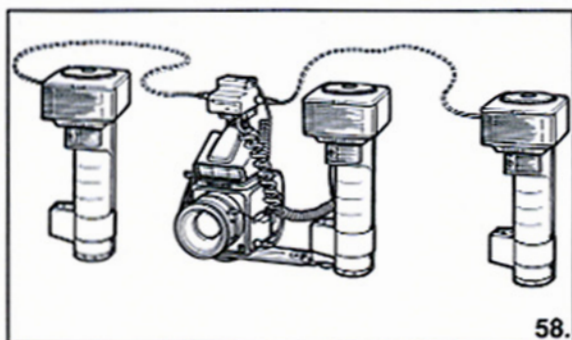

58.

Other Useful Accessories

The full range of accessories provided by METZ, W Germany, for their flash units mecablitz 45 CT 4 and 45 CL 4 are fully compatible with the PROFLASH 4504. A few of these are mentioned below.

The Metz Multiconnector SCA 305 A

Using multiple flashes has usually meant triggering and TTL control of one flash by the camera and the rest by photocell slave units unless you had access to a studio flash unit with multiple flash connections. The output of the slave units had to be controlled manually or by the flash unit's built-in automatic controls.

With the introduction of the Metz Multiconnector SCA 305 A you now have a tool for simultaneous TTL control of up to three separate flash units, provided they are all dedicated to the SCA 300 system. If more flash units are required you can interconnect or "stack" two or more Multiconnector units. Any dedicated flash can be used, but the best result by far is obtained if you use the same type of flash all over.

Setting up the Multiconnector

You will need the following additional equipment (fig. 58) to set up the Multiconnector SCA 305A with your Hasselblad 503CX, 500ELX or 553ELX:

Hasselblad Flash Adapter SCA 390

Metz Connecting Cord SCA 300A

Metz Connecting Cord SCA 305S (for PROFLASH 4504 or mecablitz 45CT4 and 45CL4) or SCA 305K (for small mecablitz units)

Metz Extension Cord SCA 305 V5

Depending on your setup you will need one or more of the connecting and extension cords.

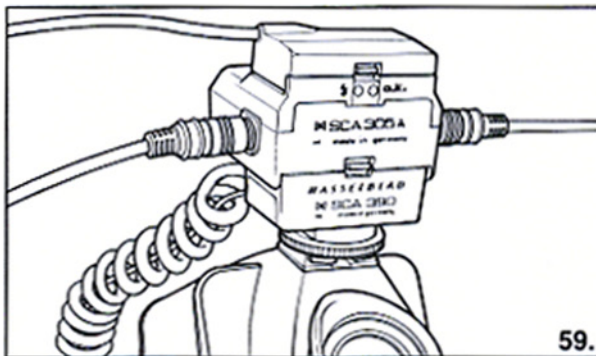

59.

The most convenient way is to attach the SCA 390 adapter on top of the prism viewfinder and connect it to the camera in the usual way. Then attach the Multiconnector to the SCA 390 adapter. Connect the 300A cord on top of the Multiconnector and insert the eight-pole female connectors of the extension and/or connecting cords in the side sockets. Now you have the option to connect PROFLASH 4504 or any other SCA 300 unit to the open connectors (fig. 59).

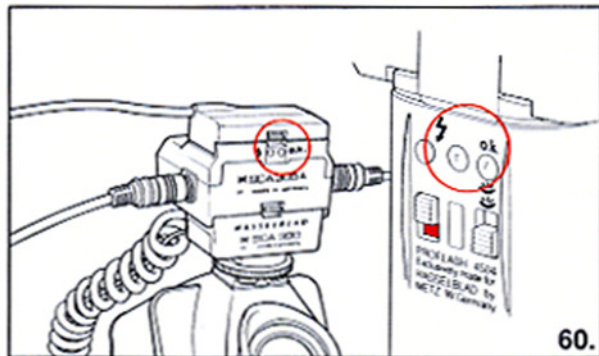

60.

Using the Multiconnector

On the back of the Multiconnector are two indicator lights corresponding to those on the back of the Proflash handle: A green "ready" light and a red "OK" light (fig. 60). Their functions are identical to those on the Proflash, only that they require all connected units to be ready to light up the "ready" light and the total output from the entire system to be sufficient to show the "OK" light. Thus, you can work with the flash units away from the camera and still have full control of the function through the indicator lights on the Multiconnector.

Set the film speed on the camera and use the system just as if it were a single TTL flash unit.

36

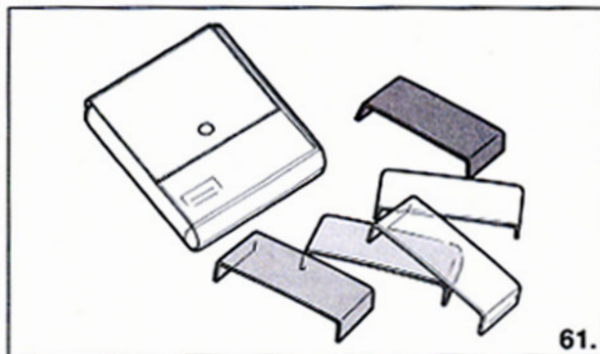

61.

Color Filter Set

A case with a set of four color filters for special illumination effects and a clear filter holder for sheet filters of any color (fig. 61).

Suggestion: Use one flash in a Multiconnector setup for a special color effect or use a single flash with a color filter as a fill-in light in a mixed-light application. The power of the single flash can easily be reduced by setting the film speed dial at a higher speed than that of the film used.

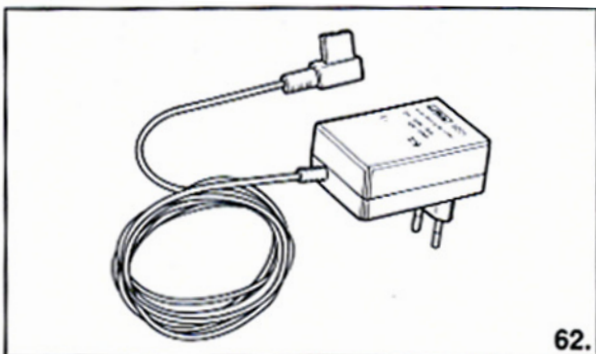

62.

AC Mains Power Supply Unit

Electronically stabilized battery eliminator (fig. 62) for direct AC mains power supply. Facilitates a full power flash interval of 18 sec. Cord length 3m (10ft).

For further information on accessories please refer to the METZ meca-blitz Product Catalog.

37

TTL Flash Close-up Range Chart

In TTL mode the flash and camera electronics controlling the light output operate by cutting off the flash when the proper amount of light has reached the film. At close ranges, however, the required amount of light usually is very small and consequently the flash duration extremely short, reaching the limits of the controlling circuit's capacity. For each combination of film speed and aperture setting there is a "near limit" which is indicated by the chart in the opposite page.

The chart is designed with three parameters:

- Film Speed
- Flash-to-subject Distance
- Camera Aperture Setting

Use two of these parameters to find the third. It also includes three different examples, indicated by the different line types.

1.To find the closest possible range:

The **dotted** lines illustrate how to find the closest possible range with an ISO 400/27° film and a lens with a smallest aperture of 22. Follow the horizontal dotted line from the ISO 400/27° position until you reach the oblique dotted line marked 22. Then follow the vertical dotted line to find the minimum range 0,7m.

2.To find the aperture for a certain distance:

The **dashed** lines illustrate how to find the aperture with an ISO 100/21° film and a flash-to-subject distance of 0,5m.

Follow the horizontal dashed line from the ISO 100/21° position until it crosses the vertical dashed line for 0,5m. There you find the oblique dashed line for the required aperture 16.

3.To find the suitable film speed under certain conditions:

The **dash-and-dot** lines illustrate how to find the appropriate film speed when the flash-to-subject distance is 1m and the aperture 4 determined by the requirement of a shallow depth-of-field.

Follow the vertical dash-and-dot line from the distance 1m until it crosses the oblique dash-and-dot line for the aperture 4. There you find the horizontal line leading to the film speed ISO 25/15°.

From the diagram you can also see that e.g. with a film speed of ISO 100/21° and an aperture of 2,8 the shortest flash-to-subject distance is as long as 3m.

TTL Flash Close-up Range Chart

Film Speed

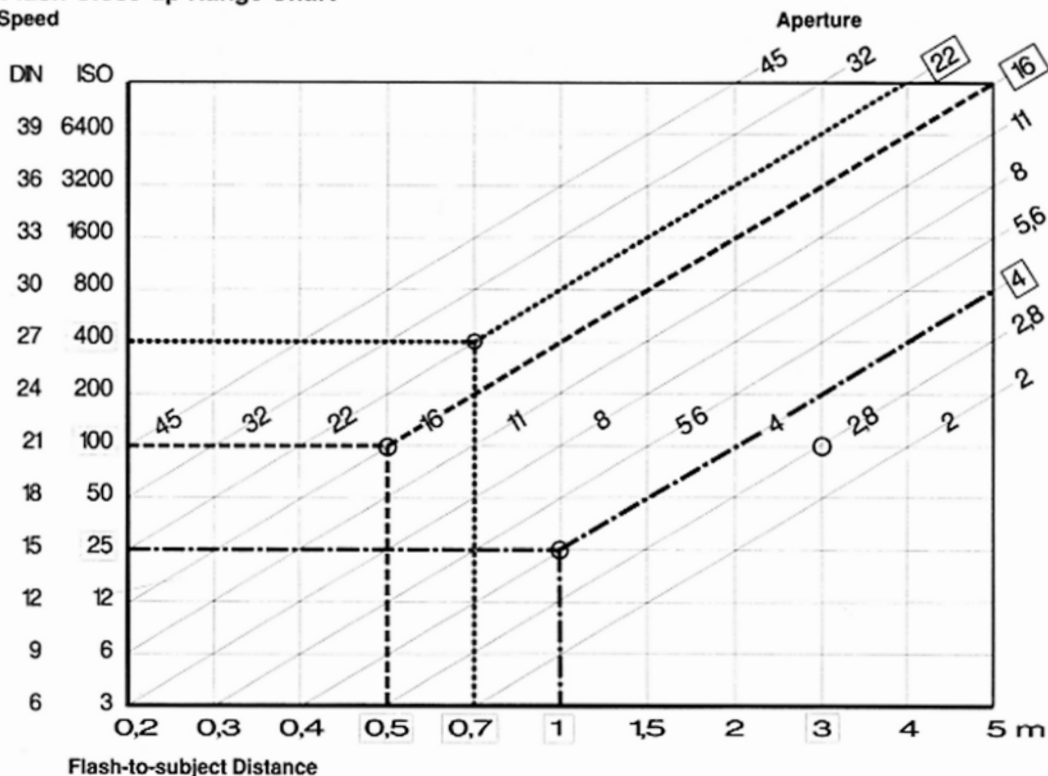

Guide Number Chart

Manual Mode, full light output

Film speed		Guide number (GN)	
ASA	DIN	Metric-system	ft-system
6	9	11	37
8	10	13	42
10	11	14	47
12	12	16	53
16	13	18	59
20	14	20	66
25	15	23	74
32	16	25	83
40	17	28	93
50	18	32	105
64	19	36	118
80	20	40	132
100	21	45	148
125	22	50	166
160	23	57	186
200	24	64	209
250	25	71	235
320	26	80	263
400	27	90	295
500	28	101	331
650	29	113	372
800	30	127	417
1000	31	142	468
1250	32	160	525
1600	33	179	589
2000	34	201	661
2500	35	226	742

40

Guide Number Correction Factors

Correction factors for calculation of guide numbers for reduced output.

M1/2: (Guide Number) x 0,7

M1/4: (Guide Number) x 0,5

W: (Guide Number) x 0,16

Compensated film speed setting for TTL cameras

NOTE: The compensation does not mean a change of the film speed. It is only a compensation for the reflection characteristics of the film surface. The change should **only** be made on the camera, not on the flash.

Bold print indicates film types which need no compensation.

Film Designation	Orig. speed	Set speed	Film Designation	Orig. speed	Set speed	Film Designation	Orig. speed	Set speed
Agfachrome 100 RS	100	100	Ilford HP-5	400	250	Kod. Vericolor Prof	400	320
Agfachrome 1000RS	1000	1000	Ilford Pan-F	50	32	Kod. Vericolor III	160	100
Agfachrome 200 RS	200	160	Ilford XP-I	400	250	Kod. Vericolor HC	100	80
Agfachrome 50 RS	50	64	Kod. Ektachr. 100	100	100	Polaroid 107	3000	1000
Agfacolor XRS 400	400	320	Kod. Ektachr. 100+	100	100	Polaroid 108	80	50
Agfacolor XRS 200	200	160	Kod. Ektachr. 200	200	200	Polaroid 665	80	50
Agfacolor XRS 1000	1000	640	Kod. Ektachr. 64	64	64	Polaroid 667	3000	1000
Agfacolor XRS 100	100	100	Kod. Ektachr. 400	400	320	Polaroid 669 Silk	80	64
Agfapan 100	100	80	Kod. Ektacolor Gold	160	125	Polaroid 669	80	50
Agfapan 25	25	16	Kod. Kodachrome 64	64	50	Polaroid 691	80	50
Agfapan 400	400	250	Kod. Kodacolor Gold	200	160			
Fujichrome RDP	100	100	Kod. Plus-X Pan	125	100			
Fujichrome RFP	50	64	Kod. T MAX 400	400	250			
Fujicolor 160 NSP	160	125	Kod. T MAX 100	100	64			
Fujicolor HR 100	100	100	Kod. Techn. Pan	25	16			
Fujicolor HR 400	400	320	Kod. Tri-X Pan	400	250			
Ilford FP-4	125	80	Kod. Tri-X Prof.	320	200			

Trouble-shooting

Your PROFLASH 4504 has been built to give you a long and trouble-free service. If however you encounter any operating difficulties because you are not familiar with the Hasselblad camera and flash system, the table below may help you to resolve them. If the problem remain you are recommended to hand the unit over to an authorized Hasselblad Service Center.

PROBLEM	POSSIBLE CAUSE	REMEDY
The green "ready" indicator does not light up within 30 seconds when the unit is switched ON or after a released flash.	The power unit is not correctly inserted.	Push the power unit firmly into the flash handle and ensure that the retaining hooks engage properly.
A) The flash unit is powered by the NiCad batteries.	The batteries are discharged.	Charge the accumulators for 5 hours. Ensure that the charging indicator is lit.
B) The flash unit is powered by AA alkaline batteries.	The AA alkaline batteries are dead. The AA alkaline batteries are not inserted correctly.	Insert fresh AA alkaline batteries. Insert the AA alkaline batteries according to the instructions.
The flash is connected to the camera with a synch cord and the green "ready" light is lit but the flash does not release when the camera is triggered.	The synch cord is not properly fitted. The synch cord is broken.	Ensure that the connectors are correctly inserted in the sockets. Replace the synch cord.
As above but the flash unit is connected to a Hasselblad 2000-series camera.	The shutter is set to a speed faster than 1/90s.	Reset the shutter to 1/90s.
The flash fires correctly but the red "OK" indicator does not light up (AUTO and TTL mode only).	The light output was not sufficient to illuminate the subject for a correct exposure. The flash unit's light sensor was obscured by some object.	Use a larger aperture setting or Change to a faster film or Move closer to the subject. Ensure that the sensor has a free view.

42

Technical Specifications

Guide No.:	Film speed ISO 100/21° Metric: 45; Feet: 148
Guide No., Winder Mode:	Film speed ISO 400/27° Metric: 14; Feet: 46
Flash Energy:	100 ws (joules)
Illumination:	Horizontally 62°, vertically 42°
With Fill-in reflector:	Horizontally 65°, vertically 45°
With Wide-angle diffuser:	Horizontally 65°, vertically 60°
Light distribution with fill-in reflector:	Main reflector 85%, Fill-in reflector 15%
Main reflector movement:	Horizontally 180° left and right Vertically 90° in 6 click-stops
Color temperature:	5600°K
Sensor image angle:	25°
Aperture settings in Automatic Mode:	2.8 - 4 - 5.6 - 8 - 11 - 16
Power source:	NiCad battery unit, rechargeable 6 pcs 1.5 V alkaline batteries size AA (LR 6) METZ Mains unit N 22
NiCad charging time:	5 hrs, inside or outside flash unit
Flash duration, seconds:	1/300° — 1/20000
1/2 power (M1/2):	1/1000
1/4 power (M1/4):	1/2500
Winder Mode (W):	1/10000
	All durations are approximate

Number of flashes (approx.)	
With NiCad battery:	50° — 2000
With high capacity alkaline batteries:	140° — 3600
With AC mains unit N 22:	Indefinite
Recycling time (approx.)	
With NiCad battery:	7° — 0.3 seconds
With high capacity alkaline batteries:	11° — 0.3 seconds
With AC mains unit N 22:	18° — 0.3 seconds
In Winder Mode (W):	2 flashes/second (NiCad pack only)
Synchronization circuit:	Low-voltage thyristor triggering
Dimensions:	H 247 x W 92 x L 102mm (9 3/4 x 3 5/8 x 4 in)
Weight:	680 g (1 lb 8 oz) without battery
NiCad battery unit:	170 g (6 oz)
	*Full flash power or M mode

43

PROFLASH 4504 Dimensions

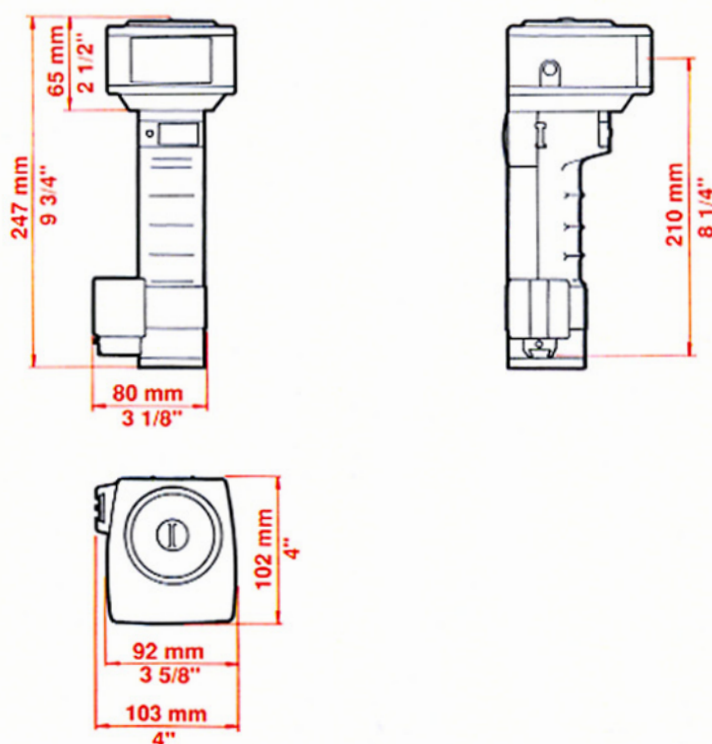

44

Suggestions for use in TTL Mode

A. The camera sensor measures over a central image area with a diameter of 40mm. If the subject fills only a minor part of this area or if an important but considerably smaller part of the subject has a different brightness than the rest of the subject, such as the faces of a darkly dressed group of people, the meter may be fooled by the dominating part of the subject and give a wrong exposure and yet give an "O.K." indication in the viewfinder and on the flash.

To avoid this you could change the film speed setting on the camera film speed dial compared to the film in use:

1. When the important part is **brighter** than the dominating surroundings it will be overexposed. Set the film speed dial to **double** the ISO setting.
2. When the important part is **darker** than the dominating surroundings it will be underexposed. Set the film speed dial to **half** the ISO setting.
3. If in the slightest doubt or just to be on the safe side about the exposure make "bracket" exposures, changing the setting of the film speed dial and exposing at half, normal and double ISO setting.

B. Use the Proflash 4504 for special effects, e.g. to make a subdued fill-in flash or to add a highlight to the subject using the flash with a colored filter:

1. Determine the correct exposure in the existing light, e.g. with the Hasselblad Meter Prism Viewfinder.
2. Set shutter speed and aperture according to this measurement.
3. Set the film speed dial to double - or even more - the speed of the film in use.
4. If possible, make "bracket" exposures according to p.A:3 above.